

THETA 750 SNAP - DRILL JIG MANUAL



READ BEFORE USE

The following instructions are designed to help you operate the THETA 750 SNAP DRILLING JIG in a safe, efficient and professional way. To ensure continual improvement, we welcome your feedback on this manual sent to info@ledrabrands.com

GENERAL NOTES

- The THETA 750 SNAP DRILL JIG is designed to be used with a battery-operated (cordless) drill ONLY set to SLOW speed.
- The THETA 750 SNAP DRILL JIG is intended for use installing the latest generation LED Puck Snap-type modules ONLY.
This includes Snap, Solo, Zero, RGBW, Wide and IP68 modules. DO NOT USE for threaded (screw-in) LED Puck installations.
- NOTE! Square pipe / flat-faced rail applications require a spacer installed in the Drill Jig. Refer to the supplementary guide: Drill Jig Flat Face Setup.
- If the Drill Jig is not functioning as expected please contact LedraBrands ASAP at (714) 259-9959
- **DO NOT USE IMPACT OR HAMMER DRILL**

CONTENTS

GENERAL NOTES	1
EQUIPMENT CHECKLIST	2
THETA 750 SNAP DRILL JIG CASE CONTENTS	3
THETA 750 SNAP DRILL JIG PARTS	4
HOW THE DRILL JIG WORKS	5
1. MARK THE LED POSITIONS	6
2. INSPECT THE CUTTER ASSEMBLY	7
3. INSTALL / REPLACE THE CUTTERS	8
4. SET THE DRILL ANGLE	9
5. LUBRICATE THE CUTTERS	10
6. CLAMP DRILL JIG TO RAIL.....	11
7. CHECK YOUR DRILL SETUP.....	12
8. DRILL THE HOLE.....	13
9. REMOVE DRILL JIG AND CLEAN.....	14
TROUBLESHOOTING GUIDE	15
DRILL JIG FLAT FACE SET UP	15



Read all safety warnings and instructions. Failure to follow instructions may result in injury.



A maximum 400rpm drill is recommended. Do not use a higher rpm drill as it will shorten the life of the cutter and cause work hardening of the rail.



Always use ear plugs or ear muffs when drilling to avoid hearing damage.



Led puck hole preparation and drilling should be carried out by skilled personnel only.



Read and observe the safety precautions and operating instructions on your chosen drill and equipment.



Drilled metal and (shavings) can be hot enough to burn and injure. Use appropriate personal protective equipment (PPE) such as goggles, gloves and safety boots.



The drill jig must be used with a battery-operated (cordless) drill only set to slow speed.



The drill jig contains sharp and fast moving parts that can cause harm if used incorrectly.



The drill jig has been designed for use with the supplied 15mm and 16mm cutters only. Do not use other cutters unless instructed.



Do not use a rotary/impact/hammer drill or such settings on your chosen drill. Drill must be set to 'drill/driver' setting and slow/low speed.



Do not clean with compressed air. This may cause shavings to be wedged between components causing issues.



Remove or replace cutters only as shown in this manual. Please notify your supplier if the cutters do not perform as described.



Do not attempt to modify the drill jig or operate it outside of the range described within this manual. Modifications or tampering with the drill jig may result in deposit not refunded.

EQUIPMENT CHECKLIST

In addition to the items supplied in the THETA 750 SNAP Drill Jig case, other items you will need include:

- Battery-operated (Cordless) Drill ONLY
- Masking Tape
- Eye Protection (safety goggles)
- Ear Protection (ear muffs or ear plugs)
- Other Personal Protective Gear (PPE) such as gloves, boots etc.



A battery-operated (cordless) drill; 400RPM maximum. We recommend using a large battery pack and spares.



Remember to wear personal protective equipment (PPE).



Masking tape

THETA 750 SNAP DRILL JIG CASE CONTENTS

Your supplied LED Puck THETA 750 SNAP Drill Jig case contains the following equipment.

Please note any irregularities with your supplier ASAP:

- 1 x Drill Jig unit pre-installed with 1 x 15 and 16mm cutters
- 1 x Flat Face Spacer (for use ONLY with Flat face / Square Pipe).
- 1 x Drilling manual (this guide)
- 2 x 15mm cutters (spares)
- 1 x 16mm cutter (spare)
- 1 x Cutter removal tool (double-sided)
- 1 x 2mm Allen (hex) key
- 1 x cutting lubricant
- 1 x 10mm nut driver
- 1 x 10mm wrench
- 1 x Insertion pliers
- 1 x File

NOTE! Please return all provided equipment to the case upon installation completion.



THETA 750 SNAP DRILL JIG PARTS

The THETA 750 SNAP Drill Jig parts labeled in the adjacent image are referred to in the following pages.

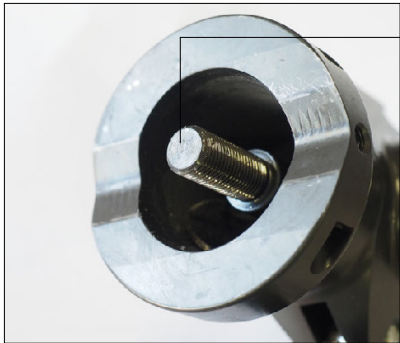

cutter end (shown here WITHOUT cutters installed)

The Drill Jig cutter assembly.



15mm cutter (left) and 16mm cutter (right; with inserted cutter spacer). Note, the cutters come pre-installed in the Drill Jig.

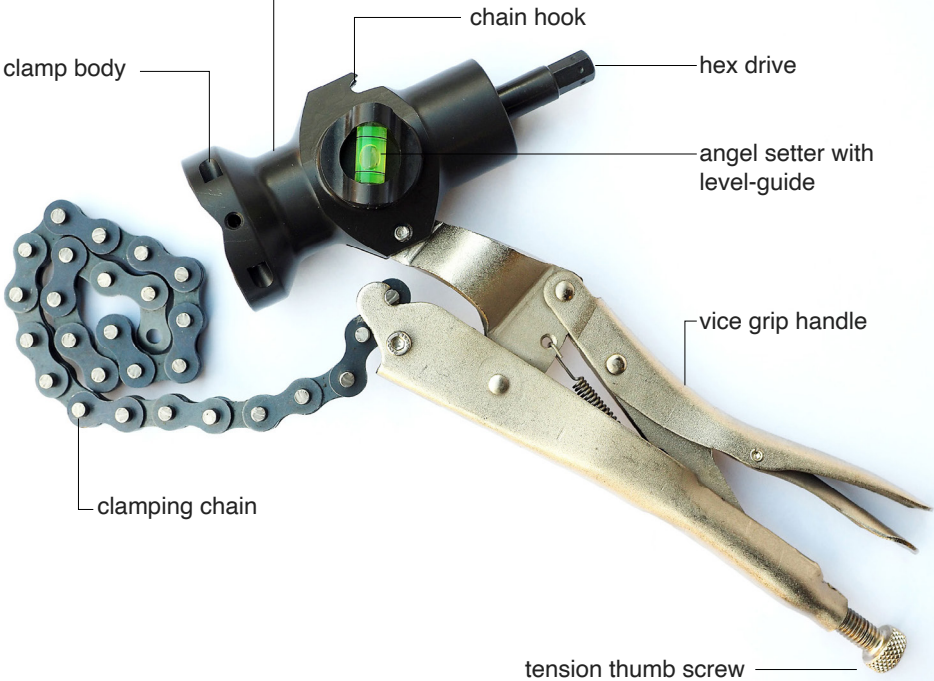

HOW THE DRILL JIG WORKS

WHAT IS THE THETA 750 SNAP DRILL JIG

The THETA 750 SNAP Drill Jig's purpose is to enable consistent and accurate drilling of metal pipe, with counterbore, and to significantly reduce installation time.

The THETA 750 SNAP Drill Jig is designed for the following:

- Use with a battery-operated (cordless) drill ONLY
- Installing the latest generation LED Puck Snap-type modules ONLY: Snap, Solo, Zero, RGBW, Wide and IP68
- Use with curved-face metal rail, or flat faced rail (spacer fitting required for flat faced-rail, *see note**)
- Cutting a hole with a 15mm diameter and a 16mm counterbore. *See Minimum Wall Thickness table.*

MINIMUM WALL THICKNESS

Observe the Drill Jig / LED Puck requirements for minimum wall thickness.

RAIL TYPE	MINIMUM THICKNESS
CURVED FACE (TUBE)	1.5mm
CURVED FACE (TUBE)	2.0mm

Table 1. Minimum wall thickness for different rail types. Contact LEDRAbrands or your distributor if your specifications are outside these minimums. *See Flat Face note below.

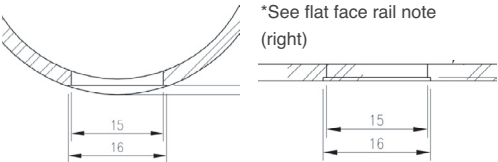

Curved Face (Tube) Rail

Flat Face (Square) Rail

THE DRILL JIG IN USE

Operating a drill attached to the THETA 750 SNAP Drill Jig will automatically drive its cutters into the cutting surface until full depth is achieved and the hole fully made. The Drill Jig will automatically cut the counterbore hole. Once cutting is achieved, reversing the drill will withdraw the cutters back inside the Drill Jig cutter assembly and into a position ready for the next hole.

COUNTER-BORING

To ensure counter-boring works as intended, make sure that your 15mm and 16mm cutter installation is correct (step 3). The result should be the LED Puck embedded flush within the rail (below).



Above: The THETA 750 SNAP Drill Jig in use. Proper use of the Drill Jig will result in a significantly faster and more professional finish.

TIP! Test your first hole on a spare piece of pipe and spare LED Puck.

***NOTE!** Square pipe / flat-faced rail applications require a spacer fitted to the Drill Jig. Refer to the supplementary document: THETA 750 SNAP Drill Jig Flat Face Setup (page 16).

1. MARK THE LED POSITIONS

- 1.1 Measure and mark the LED Puck positions on the rail using a short length of masking tape (Fig 1.1).
- 1.2 Check for interference with posts, or other obstructions. Adjust positions accordingly to avoid all interference.

NOTE! Refer to your drawing or specifications to measure the correct location and positions of the LED Puck.

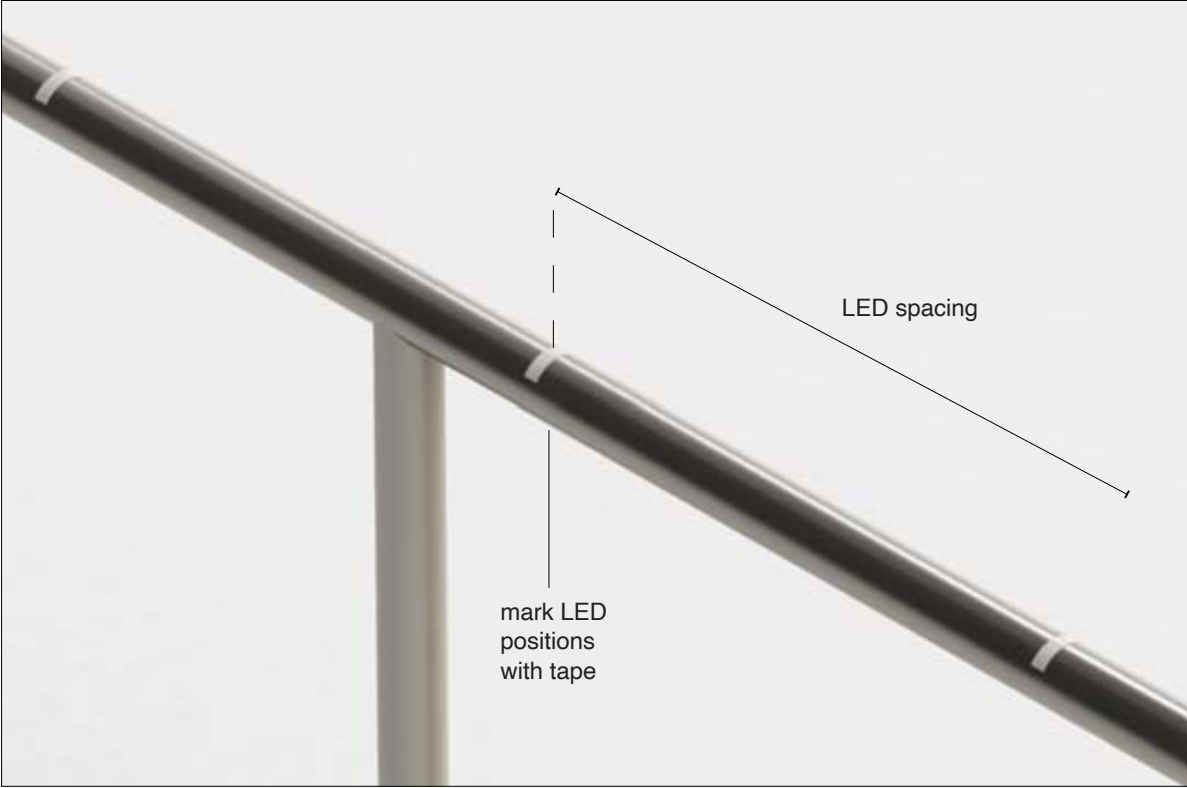

Fig 1.1. Measure and mark the LED Puck positions on the rail.

2. INSPECT THE CUTTER ASSEMBLY

The cutters are installed and ready for use in your Drill Jig. Inspect inside the cutter assembly and follow the appropriate steps to confirm your setup:

CUTTERS ARE INSTALLED

2.1 Ensure that the cutter end is fully retracted inside the cutter assembly. If not, reverse the cutter into the assembly by engaging the drill (reverse) on the Drill Jig hex drive (Fig 2.1) The cutters should NOT protrude from the cutter assembly

CUTTERS ARE NOT INSTALLED

2.2 If cutters are not yet installed (Fig. 2.2), proceed to install them as shown in step 3.

NOTE! Check if a flat face spacer is present inside the cutter assembly. ONLY use the spacer if drilling square/flat-face pipe. Refer to THETA 750 SNAP Drill Jig Flat Face Setup.



Fig. 2.1 If cutters are pre-installed, use your drill to ensure that both the hex drive and cutter end of the cutter assembly are fully retracted.

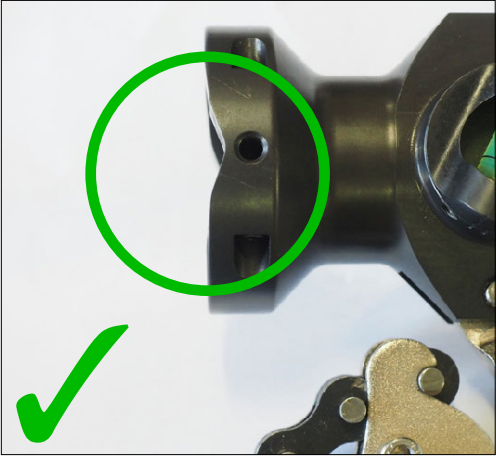

CORRECT. Cutters are installed and fully retracted inside the cutter assembly.

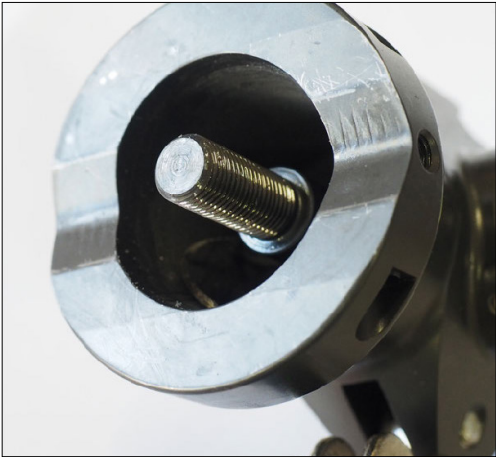
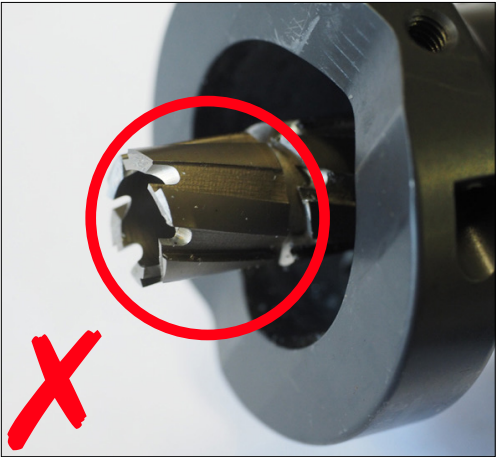
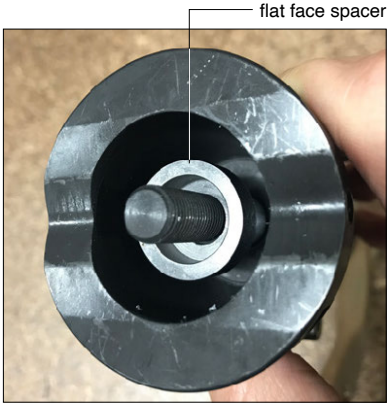

Fig. 2.2 Cutter end of the cutter assembly pictured above. The cutters are not yet installed. Proceed to cutter installation (step 3).



INCORRECT. Installed cutters should NOT remain protruding from the cutter assembly. Ensure that cutters are fully retracted inside the cutter assembly before using the Drill Jig.



The flat face spacer is used with square pipe ONLY

3. INSTALL / REPLACE THE CUTTERS

DRIVING CURVED PIPE:

Install BOTH 15mm and 16mm cutters as described. Install the 16mm cutter FIRST (begin from step 3.1)

DRILLING FLAT FACE / SQUARE PIPE

Install the flat face spacer FIRST, before installing the 16mm and 15mm cutters. See supplementary guide: THETA 750 SNAP Drill Jig Flat Face Setup (page 16).

NOTE! Before installing cutters, engage your drill on the Drill Jig's hex drive to extend the cutter end (below left). The Drill Jig is ready for cutter installation when the cutter end is FULLY EXTENDED from the Drill Jig (below right).

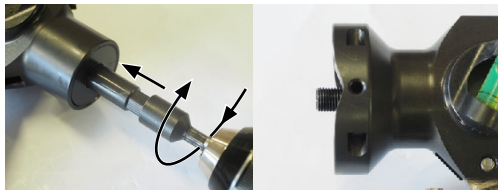

Fig. 3.1 Use your drill to fully extend the cutter end (above right) BEFORE cutter installation.

INSTALLING THE 16MM CUTTER COUNTERBORE CUTTER:

- 3.1 Extend the Drill Jig's cutter end / thread using your drill. Ensure to fully extend the cutter end (Fig. 3.1).
- 3.2 On the 16mm cutter, ensure the cutter spacer is carefully inserted into the cutting side of the 16mm cutter (see Drill Jig Parts).
- 3.3 Lightly screw the 16mm cutter onto the threaded cutter end of the Drill Jig's cutter assembly.
- 3.4 Secure the 10mm wrench on the hex drive and the cutter removal tool's 16mm end to the cutter (Fig. 3.4)
- 3.5 While securing the spanner, rotate the cutter removal tools lever clockwise to tighten the cutter onto the cutter end of the Drill Jig until it is firm and secure.

INSTALLING THE 15MM CUTTER:

- 3.6 Lightly screw the 15mm cutter onto the threaded cutter end of the Drill Jig's cutter assembly.
- 3.7 Secure the 10mm wrench on the hex drive and the cutter removal tool's 15mm end to the cutter.
- 3.8 While securing the wrench, use the cutter removal tools lever to rotate the cutter clockwise onto the cutter end of the shaft until it is firmly secure.

REMOVING / REPLACING THE CUTTERS:

Ensure to fully EXTEND the cutter-end of the Drill Jig before cutter removal. Proceed to reverse the described steps for installing the 16mm and/or 15mm cutters. Use a counter-clockwise turn on the cutter removal tool.

TIP! Place the Drill Jig on a flat surface to make cutter installation or removal easier.

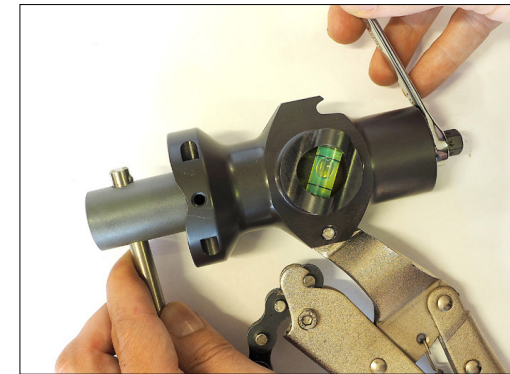

Fig. 3.4 Use the cutter removal tool and wrench provided to remove or secure the cutters. Note the cutter removal tool's 15mm side (shallow) and 16mm side (deep).

4. SET THE DRILL ANGLE

The Drill Jig has a level that enables drilling holes into the rail at a consistent angle.

The drilling angle can be set at 10° intervals from the vertical down position. Typical installation angles are

- Standard beam (ST): 30
- Vertical down beam (AS/VA): 0° or 10°

Follow the below instructions to adjust the angle setter:

- 4.1 Loosen the two allen screws on the angle setter with the supplied Allen key until you can freely turn the angle setter (Fig. 4.1).
- 4.2 Turn the angle setter to the desired angle. Note that each indicator mark represents increments, or an offset, of 10°.
- 4.3 Tighten the allen screws to lock the angle setter in position.

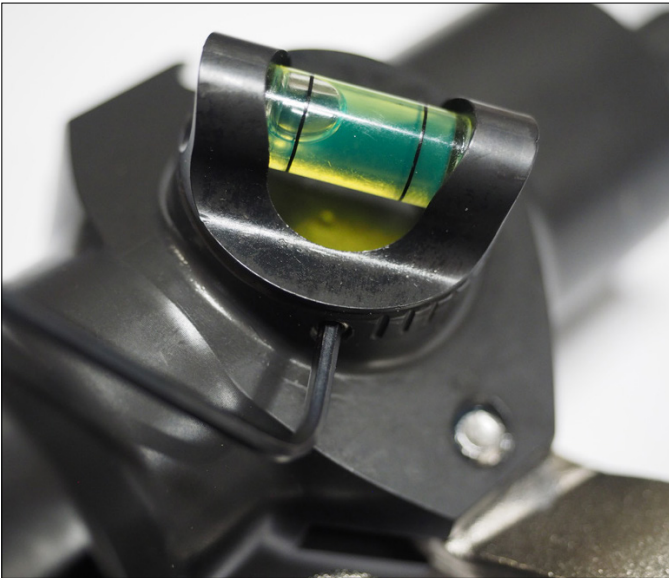
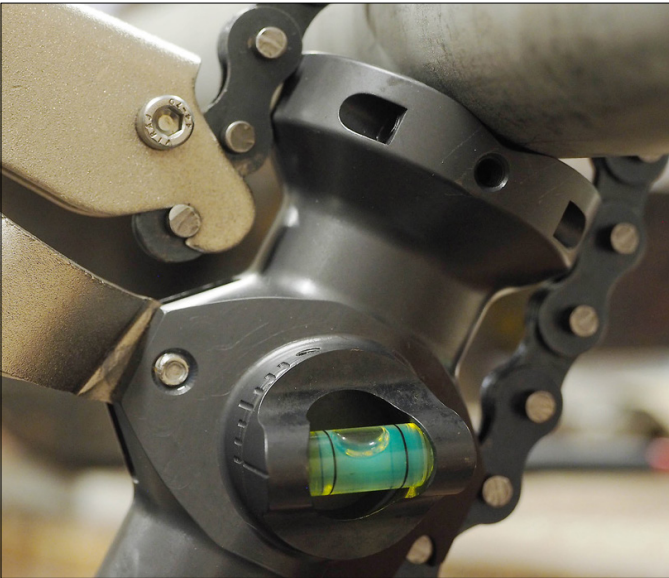

Fig. 4.1 Loosen the two allen screws with the allen key to adjust the angle setter.



Above: The drill Jig's level bubble should be centered before the drilling to enable consistent angle drilling at your set angle.

5. LUBRICATE THE CUTTERS

The Drill Jig cutters must be lubricated before drilling EACH hole.

5.1 Use the supplied cutting lubricant stick to apply a small amount of lubricant onto the cutter as shown (Fig. 5.1).

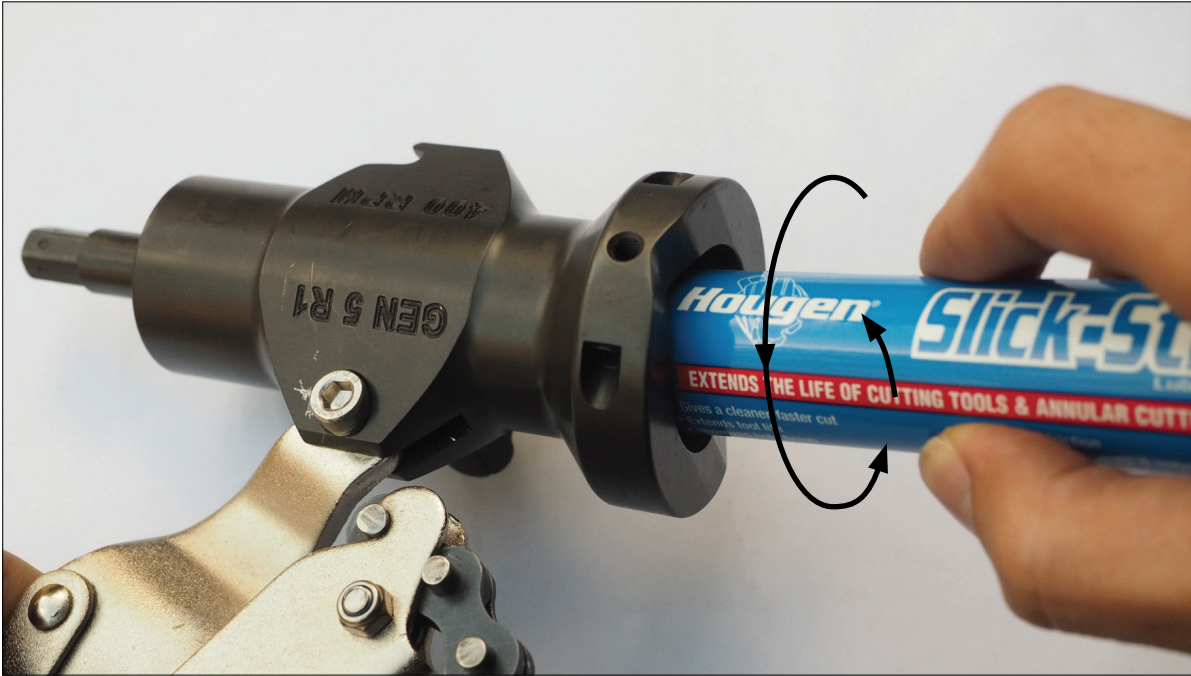

5.1 IMPORTANT! Lubricate the cutters before drilling each hole. A light twist action will supply a sufficient amount.

6. CLAMP DRILL JIG TO RAIL

6.1 REMINDER! Ensure you have applied cutting lubricant to the cutter.

6.2 Align the Drill Jig's clamp body to the tape position and wrap the clamping chain around the rail. Engage the chain with the Drill Jig's chain hook.

NOTE! If rail is painted-protect the paintwork from the clamp body/chain with a suitable tape or cloth.

TIP! Open the vice grip handles fully to enable easier engagement of the chain and chain hook.

6.3 Adjust the clamp tension as needed using the handle's tension thumb screw.

6.4 Adjust the rotation of the clamp body until the angles setter's level indicator is centered.

6.5 Squeeze the vice grip handles together to lock the Drill Jig in position. Check that the clamp body is firmly secure on the rail with no lateral movement, and confirm that the alignment and level is still correct.

NOTE! Ensure the clamping chain is in a central position and that it is not touching the cutter assembly or the vice grip once the grip is engaged. If it is touching, tension may be too loose. Adjust the tension (see step 6.3).

TIP! Once the correct clamp position/tensioning has been achieved, mark the chain with permanent marker as a reminder of where to engage the chain.

TIP! The Drill Jig can be rotated/reversed 180° to enable a second clamping orientation. Choose the appropriate orientation to prevent interference with vertical rail poles. Note, if reversing the Drill Jig in position, the angles setter must be adjusted to opposite axis/negative position (see step 4).

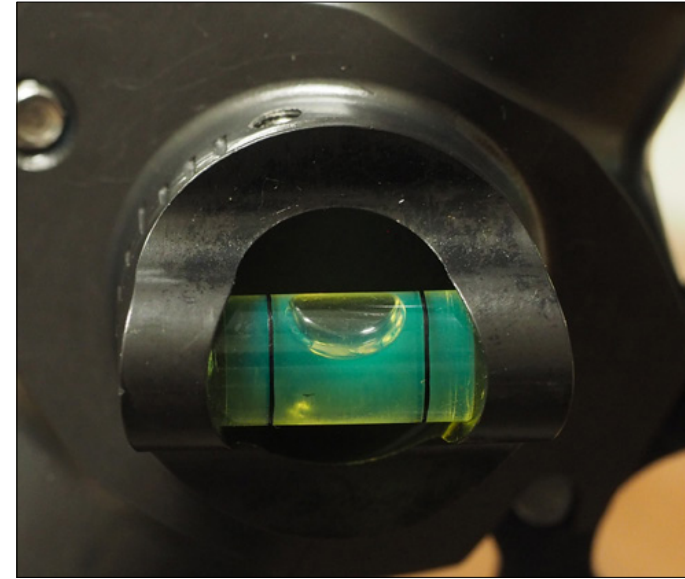
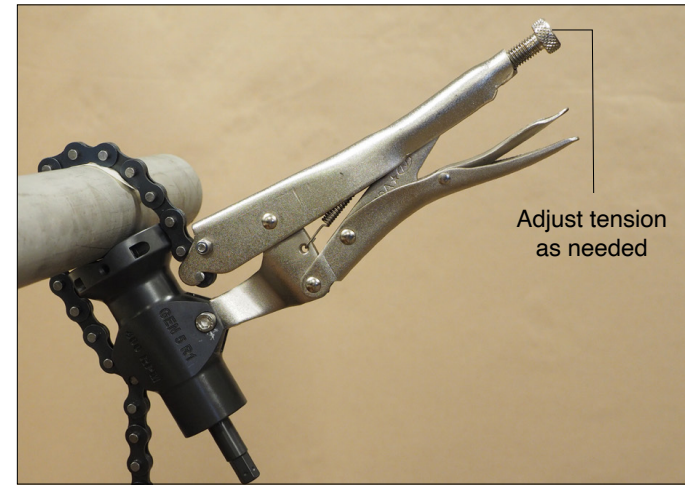

Fig. 6.2 - 6.5 Align clamp body with the tape and engage the chain hook and clamping chain. Ensure the level bubble remains centered.



Above: The clamping chain is secure, in a central position, and is not touching the engaged vice grip or the central section of the cutter assembly.



Adjust tension to ensure the clamp body is secure on the rail.

Adjust tension as needed

7. CHECK YOUR DRILL SETUP

The Drill Jig is designed to be used with a battery-operated (cordless) drill ONLY.

BEFORE YOU DRILL:

7.1 Check that the 10mm driver bit is secure in the drill and that the chuck is tight.

7.2 Check that your drill is set to

- LOW / SLOW speed / RPM
- The "DRILL" setting
- Clockwise direction
- The highest torque setting

7.3 Put on your eye protection and any other appropriate PPE.

NOTE! REMINDER! Confirm you have applied lubrication to Drill Jig cutter (step 5).

NOTE! Drill should be set to the LOW speed setting. A MAXIMUM 400 RPM drill is recommended. Higher speeds will reduce cutter life and increase the chance of work hardening.

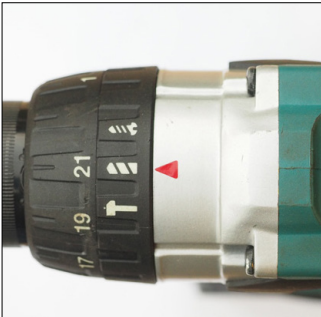
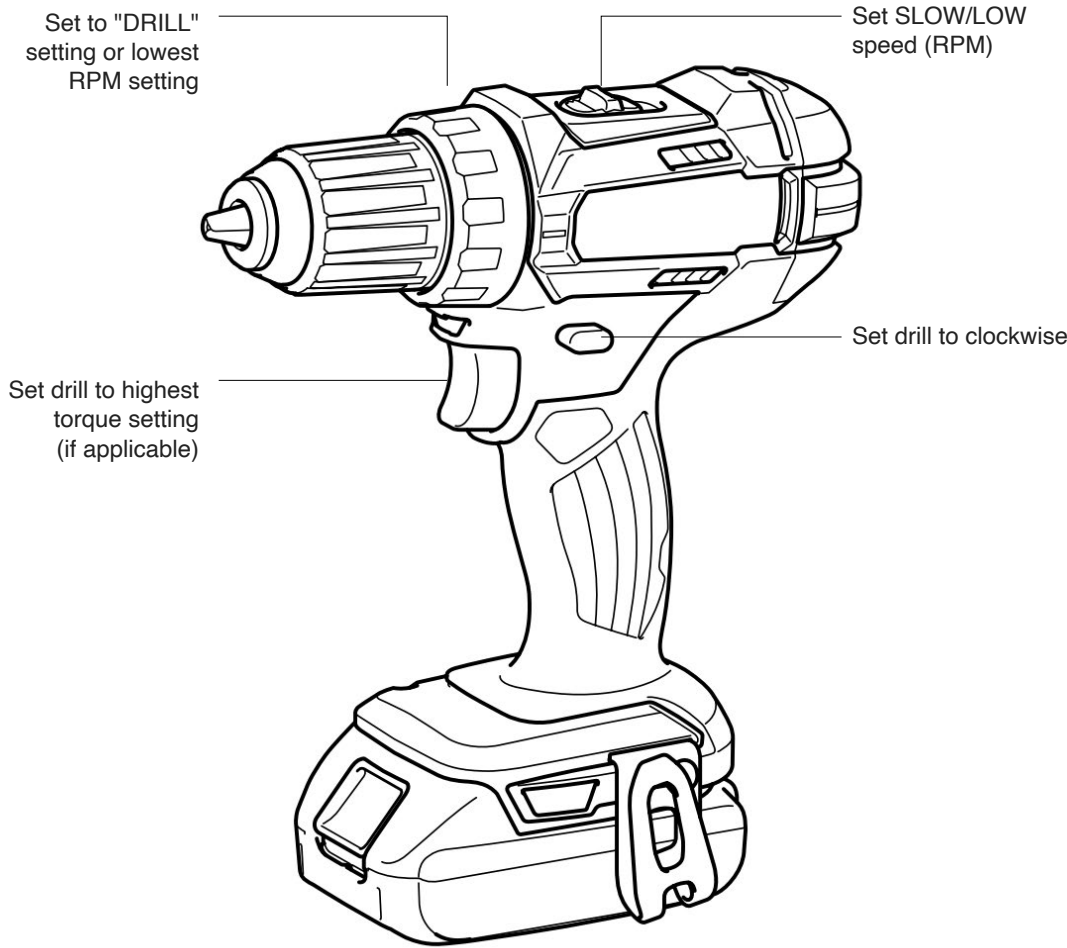

Above: our example drill is set to "Drill"; high torque; and LOW speed (1)

Above: Check the 10mm driver bit is secure



Read and observe the safety precautions and operating instructions on your chosen drill and equipment.



Drill jig must be used with a battery-powered (cordless) drill only. Do not use a mains powered drill.



Do not use a rotary/impact/hammer drill or such settings on your drill. Drill must be set to drill setting and a low drill speed (maximum of 400rpm).

8. DRILL THE HOLE

- 8.1 Connect the drill's 10mm nut driver (female) to the matching (male) hex drive on the Drill Jig (Fig. 8.1)
- 8.2 Engage the drill. **DON NOT FORCE OR PUSH THE DRILL.** Use light pressure to keep the socket engaged. **STOP DRILLING** once the hex drive has fully receded into the cutter assembly (Fig. 8.2).

NOTE! The resistance will vary during the cut as the cutters penetrate the metal. This is normal.

- 8.3 Switch the drill to **REVERSE**, and engage the drill to back out the cutters. Ensure the hex drive is fully retracted from the cutter assembly (Fig. 8.3).

NOTE! When reversing, if the drill spins and/or the hex driver does not retract, offset the angle of the drill slightly 1-2° while reversing. The drill and hex driver should now reverse.

NOTE! Ensure your drill battery is charged/changed as needed as this will keep drill times efficient and the Drill Jig operating effectively.



Fig 8.1 Do NOT force/push the drill. Use light pressure only to keep the socket engaged.



Fig 8.2 STOP drilling once the hex drive has fully receded inside the Drill Jig.



Fig 8.3 Set drill to reverse and back out the cutters / hex drive until it is fully retracted.

9. REMOVE DRILL JIG AND CLEAN

- 9.1 Open the vice grip and disengage the clamping chain to remove the Drill Jig from the rail.
- 9.2 Inspect inside the cutter assembly for presence of a slug. If present, REMOVE the slug from the cutter with pliers (Fig 9.2).
- 9.3 Remove any shavings around the cutters with the supplied pliers. Shake out any remaining shavings. Do NOT use compressed air to clean.
- 9.4 File the hole with the supplied file to remove burrs. Wipe rail clean with a cloth.
- 9.5 Go to the next hole and repeat from step 5.

NOTE! Check that you have removed the slug after EACH hole drilled. If the slug is stuck, use pliers to remove.

NOTE! Be sure to collect shavings and other waste from the site and dispose responsibly.

TIP! A good time to lubricate the cutters for the next hole is just AFTER cleaning the cutter assembly.



After drilling EACH hole, inspect the cutter assembly. Check for a slug and shaving build up (present in the above image).

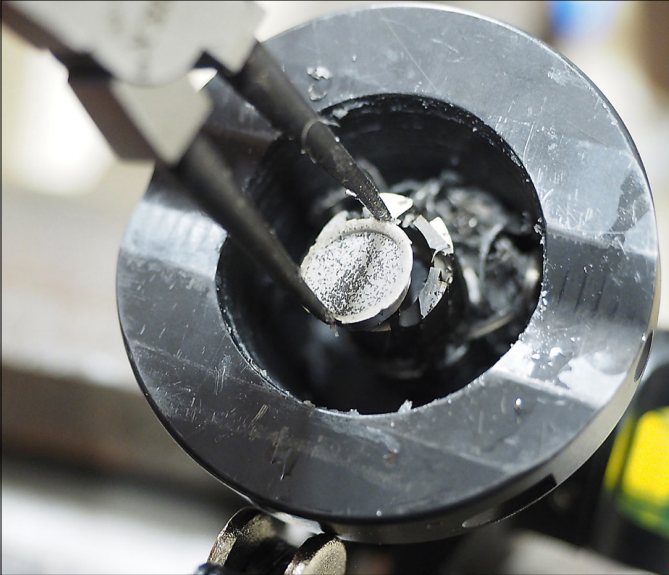

Fig 9.2 IMPORTANT! REMOVE the slug and shavings with pliers.



Slug and shavings can be hot enough to burn And injure. Use appropriate personal protective Equipment (PPE) such as goggles, gloves, and Safety boots.



Do not clean the cutter assembly with compressed air. This may cause shavings to be wedged between components, causing issues.



Ensure to inspect the cutters and remove the slug after each hole is drilled.

TROUBLESHOOTING GUIDE

ISSUE	SOLUTION
The drill spins when reversing/ the Drill Jig hex drive does not retract when reversing and appears stuck.	The hex drive is not disengaging from the cutters. To resolve, offset the angle of the drill slightly (1-2°) while reversing. The hex drive should now disengaging and retract.
The cutters do not cut/takes a long time to cut.	<ol style="list-style-type: none"> 1. Confirm a slug is not present/stuck inside the cutter assembly. 2. The cutters may be blunt. Refer to Install/Replace the Cutters (step 3).
Shaving coloring appears unusual.	<ol style="list-style-type: none"> 1. The Drill speed (RPM) is too high. Lower the drill speed. 2. There is not enough lubrication on the cutters. Lubricate the cutters (step 5) 3. The cutters are blunt/ damaged. Replace the cutters (step 3).

NOTE! If you have an issue that is not identified/resolved here, please contact your supplier or Ledra Brands for support

DO NOT attempt to modify the Drill Jig or operate it outside of the range described within this manual. If the Drill Jig is not functioning as expected please contact Ledra Brands ASAP at (714) 259-9959.

 Do not attempt to modify the drill jig or operate it outside of the range described within this manual. Contact ledrabrands ASAP if the drill jig is not operating as expected.

DRILL JIG FLAT FACE SET UP

THE FLAT FACE SPACER

Square pipe/flat-faced rail applications require a spacer fitted inside the Drill Jig.

The Drill Jig should come pre-fitted with the required spacer, however be sure to confirm it is installed, and to reinstall it as described when removing/replacing the cutters.

INSTALLING THE FLAT FACE SPACER

1. The Drill Jig cutter assembly is ready for installing the spacer when there are NO cutters and the cutter end is FULLY EXTENDED (see Removing the Cutters in step 3).
2. Simply insert the flat face spacer (tapered end first, as pictured) into the back of the Drill Jig's cutter assembly.
3. Continue with installing the cutters. Refer to Install/Replace the Cutters (step 3 in this manual).

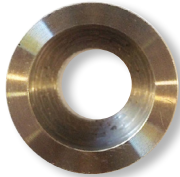

Above : the flat face spacer.

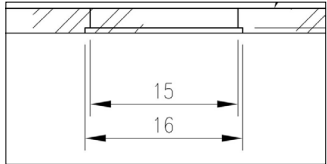

Flat face (square) rail applications require the flat face spacer installed in the Drill Jig.

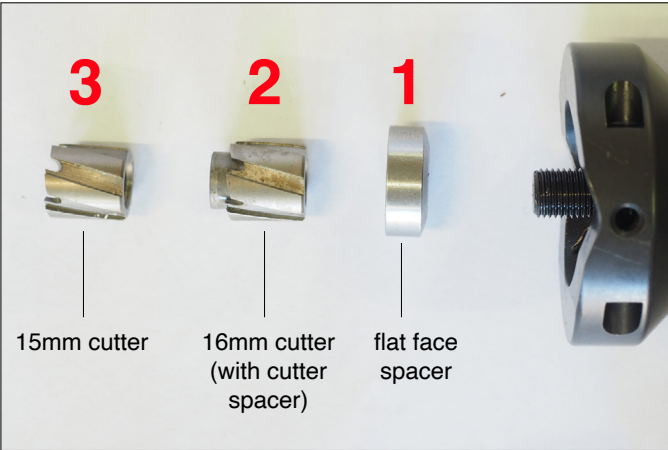

The flat face spacer is installed FIRST, followed by the cutter installation (see step 3). Remember to fully extend the cutter end of the Drill Jig (as shown).